

# Dynamic Thermal and Relative Humidity Model for a Polymer Electrolyte Membrane Fuel Cell Stack

Alexander Headley, Dongmei Chen  
University of Texas at Austin



Cockrell School of Engineering

## Introduction

Proton-Exchange-Membrane (PEM) fuel cells are a promising technology for reduction of pollution and dependence on fossil fuel in power generation applications that require a quick transient response. Ongoing research of PEM fuel cells has demonstrated staggering improvement in the last couple of decades. There are still significant challenges, however, particularly thermal and humidity management inside the fuel cell with varying operating conditions and electrical load demands. We are developing a dynamic, control-oriented model for both temperature and humidity levels which greatly affect fuel cell performance and life.

## PEM FC Challenges

- **Humidity sensitivity**
  - Poor humidity control can cause
    - Hot spots in the membrane
    - Liquid water blockages in the channel plate
- **Temperature Sensitivity**
  - Optimal at 80 Celsius
  - Can increase the voltage overpotential, thus reducing the overall fuel cell efficiency

## Temperature Methodology

The model is a first-law, control-oriented, dynamic thermal model that describes the transient response of the temperatures inside the anode, cathode, and coolant channels, as well as the fuel cell body. Four control volumes (CVs) are defined (as shown in Fig. 1): the anode channel CV, the cathode channel CV, the fuel cell body CV, and the coolant channel CV. Each CV temperature is calculated based on the conservation of energy and mass.

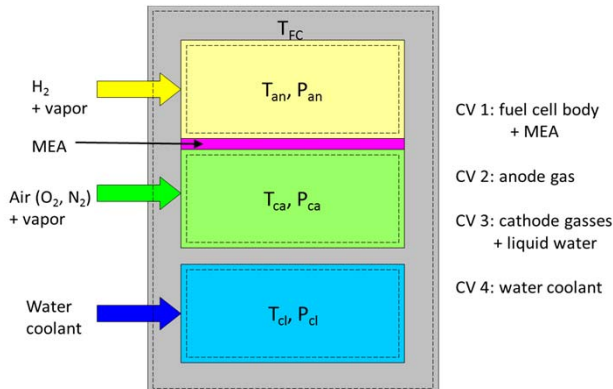

## Relative Humidity Methodology

Using the results of the thermal model, RH modeling is based solely on saturation limits for simplicity. Water input goes to vapor if  $PH_2O < P_{sat}$ , to liquid if  $PH_2O > P_{sat}$ . All of the generated water is assumed to go to the cathode. This is very sensitive to temperature fluctuations, so the accuracy of the temperature model is key.

## Experimental Tuning and Validation

Experiments were conducted to validate the developed dynamic thermal model. The PEM fuel cell stack utilized consists of 30 cells with five-layer membrane electrolyte assemblies (MEAs), each with a surface area of approximately 50 cm<sup>2</sup>. The flow fields are machined graphite plates having serpentine line flow patterns, with the anode and cathode flow field passages in a cross flow configuration. Hydrogen of 99.999% purity was used for the experiments.

For the RH testing, Vaisala RH sensors were installed in the inlet and outlet for the cathode channel. Experiments must be low RH to avoid liquid fouling of the sensors. An initial test was run in order to calibrate the model, and the requisite adjustments were validated with data from a second test.

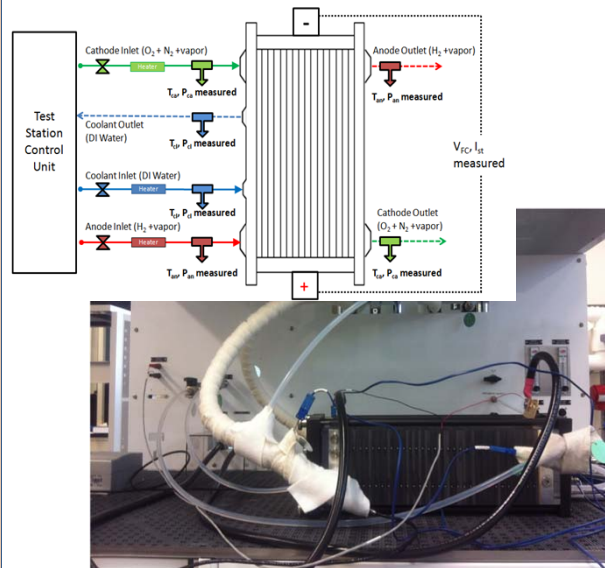

## Results

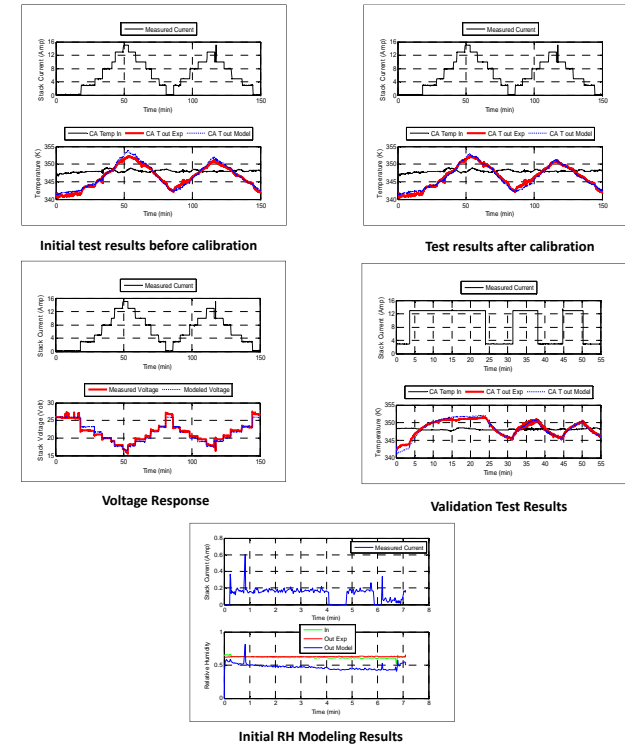

## Conclusions

The model predicts the dynamic thermal and electrical response of the fuel cell system with a good degree of accuracy as compared to experimental results. This control-oriented model is low order and based on lumped parameters, which makes the computational expense low. Formulation of this model enables the development of control algorithms to achieve optimal thermal management and stack performance. More tuning is required for the relative humidity model, given the changes to the experimental setup to accommodate the sensors.

## Further Work

- Completion of tuning for the RH model
- Analysis and modeling of porous membrane support layer
  - Integration into current PEMFC model